

## HOSE 400PSI



TUBE : OIL MIST RESISTANT SYNTHETIC RUBBER.  
 REINFORCEMENT : MULTIPLE LAYERS OF SPIRAL SYNTHETIC YARN.  
 COVER : YELLOW AND ABRASION RESISTANT RUBBER.  
 APPLICATION : AIR/WATER HOSE FOR USING IN DEMANDING ENVIRONMENTS SUCH AS MINING, CONSTRUCTION AND INDUSTRIAL APPLICATIONS.  
 TEMPERATURE RANGE : -40°C~-+100°C (-40°F~+212°F)

TYPE	SIZE	ID (mm)		OD (mm)		WP		BP		W	L
		inch	min	max	min	max	bar	psi	bar	psi	g/m
YA12-3-F-4	1/2"	12.6	13.8	21.8	23.8	28	400	84	1200	460	50/100
YA16-3-F-4	5/8"	15.6	16.8	24.4	26.4	28	400	84	1200	510	50/100
YA19-3-F-4	3/4"	18.6	19.8	28.8	30.8	28	400	84	1200	660	50/100
YA25-3-F-4	1"	24.6	25.2	36.5	38.5	28	400	84	1200	810	50/100
YA32-3-F-4	1-1/4"	31.8	32.4	42.8	45.2	28	400	84	1200	1090	50/100
YA38-3-F-4	1-1/2"	37.8	38.4	50.8	53.2	28	400	84	1200	1470	50/100
YA51-3-F-4	2"	50.8	51.4	63.8	66.2	28	400	84	1200	2060	50/100

Remark:300PSI available

## FITTING

UNIVERSAL CLAW COUPLINGS WITH FERRULES (USA TYPE)

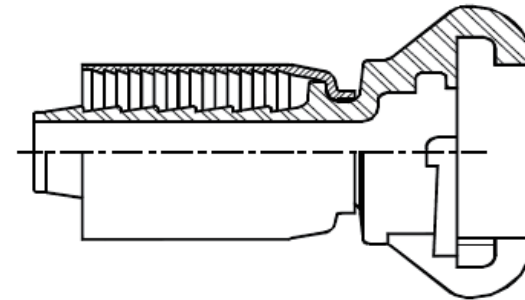
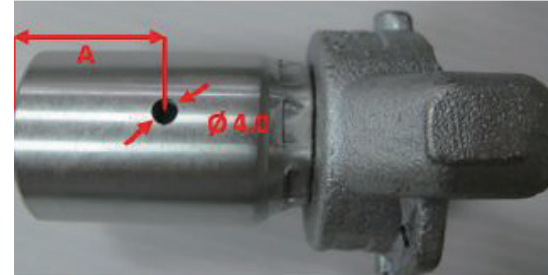

Size	Carbon Steel	Ferrule		Ferrule		Ferrule hole dimensions	
	Part NO.	I.D.	O.D.	O.D.	A	A	A
1/2"	FHE-050-SP	1.05"	26.6mm	1.20"	30.6mm	0.98"	25.0mm
3/4"	FHE-075-SP	1.34"	34.0mm	1.50"	38.0mm	1.30"	33.0mm
1"	FHE-100-SP	1.55"	39.3mm	1.70"	43.3mm	1.77"	45.0mm